

FUJITSU ELECTRIC

**SPLIT TYPE
ROOM AIR CONDITIONER
WALL MOUNTED type**

SERVICE MANUAL



Models

Indoor unit

RSB09LDC

RSB12LDC

Outdoor unit

ROS09LDC

ROS12LDC

CONTENTS

SPECIFICATIONS.....	1
DIMENSIONS.....	2
REFRIGERANT SYSTEM DIAGRAM.....	3
CIRCUIT DIAGRAM.....	4
INDOOR PCB CIRCUIT DIAGRAM.....	5
OUTDOOR PCB CIRCUIT DIAGRAM....	8
ERROR CONTENTS.....	10
DISASSEMBLY ILLUSTRATION.....	11
PARTS LIST.....	14
STANDARD ACCESSORIES.....	16

SPECIFICATIONS

TYPE	COOL & HEAT INVERTER	
INDOOR UNIT	RSB09LDC	RSB12LDC
OUTDOOR UNIT	ROS09LDC	ROS12LDC
COOLING CAPACITY	2.60 kW	3.50 kW
HEATING CAPACITY	3.60 kW	4.80 kW

ELECTRICAL DATA

POWER SOURCE		230 V	230 V
FREQUENCY		50 Hz	50 Hz
RUNNING CURRENT	COOLING	2.9 A	4.3 A
	HEATING	3.9 A	5.5 A
INPUT WATTS	COOLING	0.61 kW	0.91 kW
	HEATING	0.81 kW	1.22 kW
E.E.R.	COOLING	4.26 kW/kW	3.85 kW/kW
COP	HEATING	4.44 kW/kW	3.93 kW/kW
MOISTURE REMOVAL		1.3 L/hr	1.8 L/hr
AIR CIRCULATION -High	COOLING	560 m3/hr	595 m3/hr
	HEATING	605 m3/hr	630 m3/hr

COMPRESSOR

TYPE	Hermetic type, 4 pole, 3 phase, DC inverter motor, Rotary		
DISCRIMINATION	DA89X1C - 20FZ		
REFRIGERANT	R410A	950 g	1,050 g

FAN MOTOR

POWER SOURCE		230 V	230 V
INDOOR UNIT (cool / heat)	HIGH2	1,340 / 1,430 r.p.m.	1,400 / 1,470 r.p.m.
	HIGH-SPEED	1,300 / 1,390 r.p.m.	1,370 / 1,440 r.p.m.
	MED-SPEED	1,120 / 1,200 r.p.m.	1,150 / 1,200 r.p.m.
	LOW-SPEED	950 / 1,000 r.p.m.	950 / 1,000 r.p.m.
	QUIET	700 / 760 r.p.m.	700 / 760 r.p.m.
OUTDOOR UNIT (cool / heat)	HIGH2	820 / 760 r.p.m.	820 / 820 r.p.m.
	HIGH-SPEED	760 / 680 r.p.m.	760 / 680 r.p.m.

" HIGH2 " means when ability measurement.

DIMENSIONS

INDOOR UNIT	H x W x D	283 x 790 x 230 mm
OUTDOOR UNIT	H x W x D	540 x 790 x 290 mm

WEIGHT

INDOOR UNIT	Gross / Net	12 / 9.5 kg	12 / 9.5 kg
OUTDOOR UNIT	Gross / Net	38 / 34 kg	40 / 36 kg

NOISE LEVEL

INDOOR UNIT (Cool / Heat)	High 2	40 dB / 41 dB	42 dB / 42 dB
	High 1	39 dB / 40 dB	41 dB / 41 dB
	Med	34 dB / 35 dB	35 dB / 35 dB
	Low	29 dB / 28 dB	29 dB / 28 dB
	Quiet	20 dB / 21 dB	20 dB / 21 dB
OUTDOOR UNIT (Cool / Heat)	High 2	48 dB / 50 dB	49 dB / 51 dB
	High 1	47 dB / 48 dB	47 dB / 49 dB

REFRIGERANT (R410A)

FULL CHARGE AMOUNT	Pipe Length 15 m	950 g	1,050 g
	20 m	1,050 g	1,150 g
ADDITIONAL REFRIGERANT		20 g / m	20 g / m
MAXIMUM PIPING HEIGHT		15m	15m

DIMENSIONS

Models :
RSB09LDC / ROS09LDC
RSB12LDC / ROS12LDC

(unit : mm)

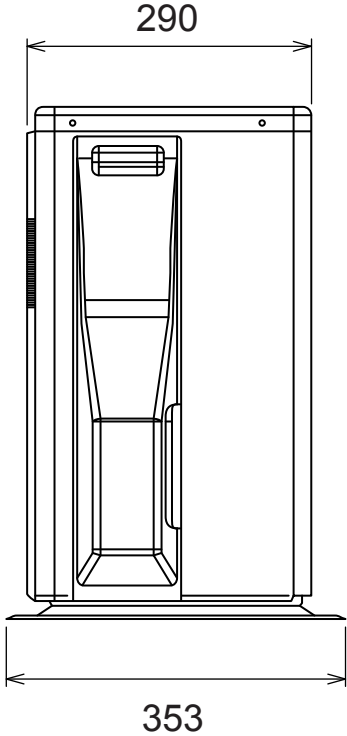
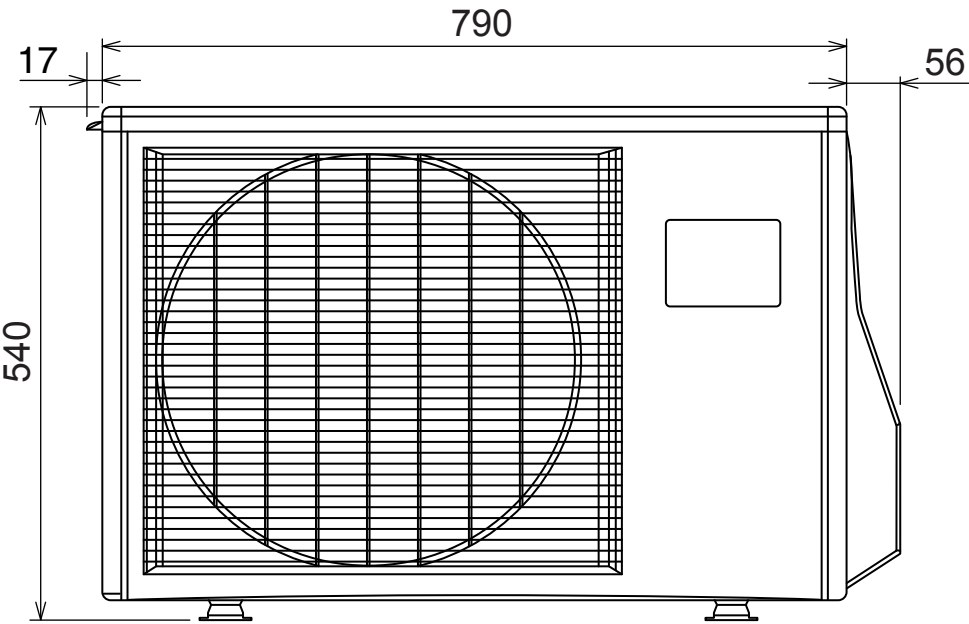
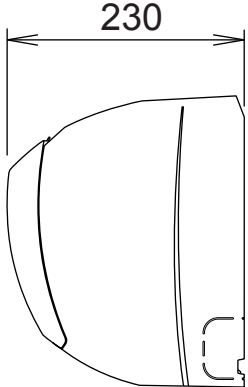
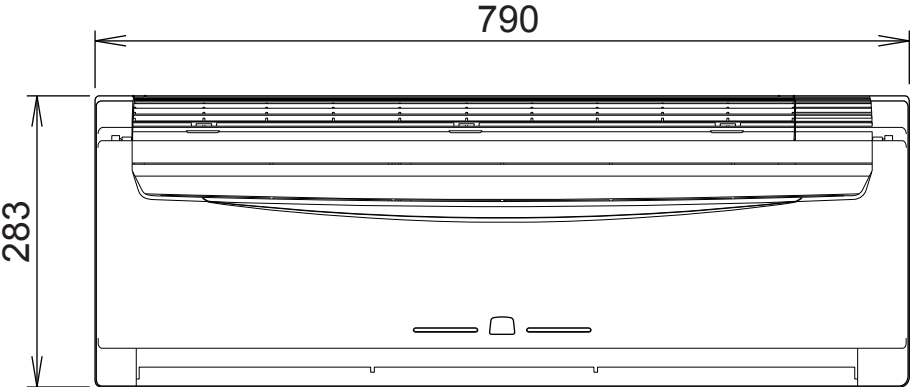

REFRIGERANT SYSTEM DIAGRAM

Models :
 RSB09LDC / ROS09LDC
 RSB12LDC / ROS12LDC

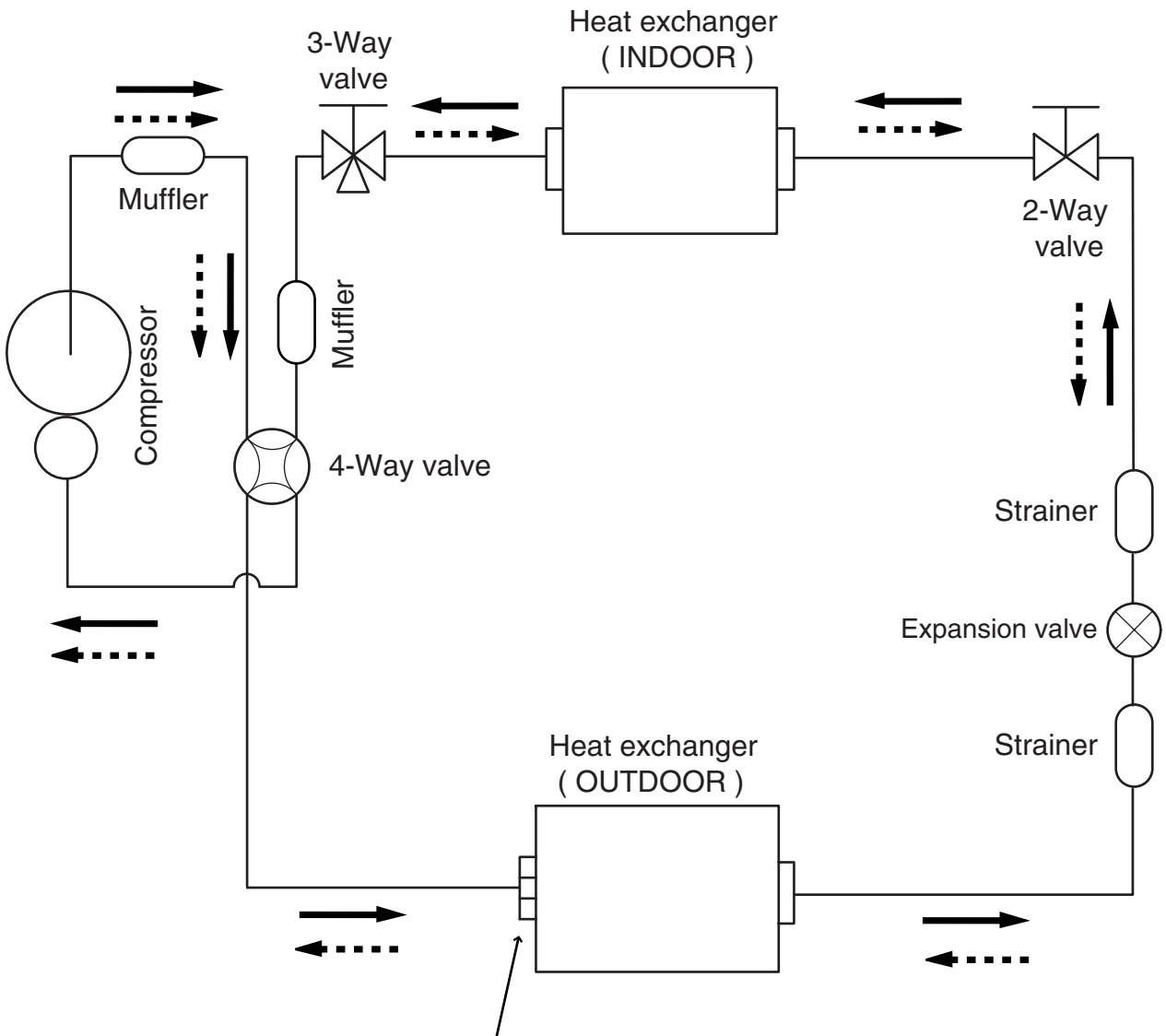

ROS09LDC : 2 pass
 ROS12LDC : 4 pass

—————> Cooling
 - - - - -> Heating

Refrigerant pipe diameter
 Liquid : 1/4" (6.35 mm)
 Gas : 3/8" (9.52 mm)

CIRCUIT DIAGRAM

Models :

RSB09LDC / ROS09LDC

RSB12LDC / ROS12LDC

INDOOR UNIT

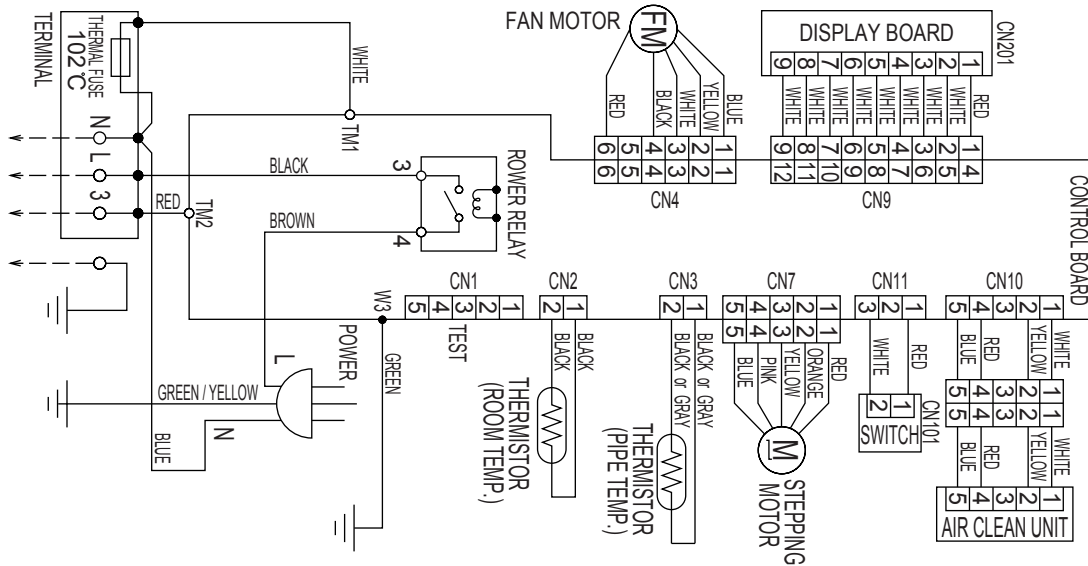

OUTDOOR UNIT

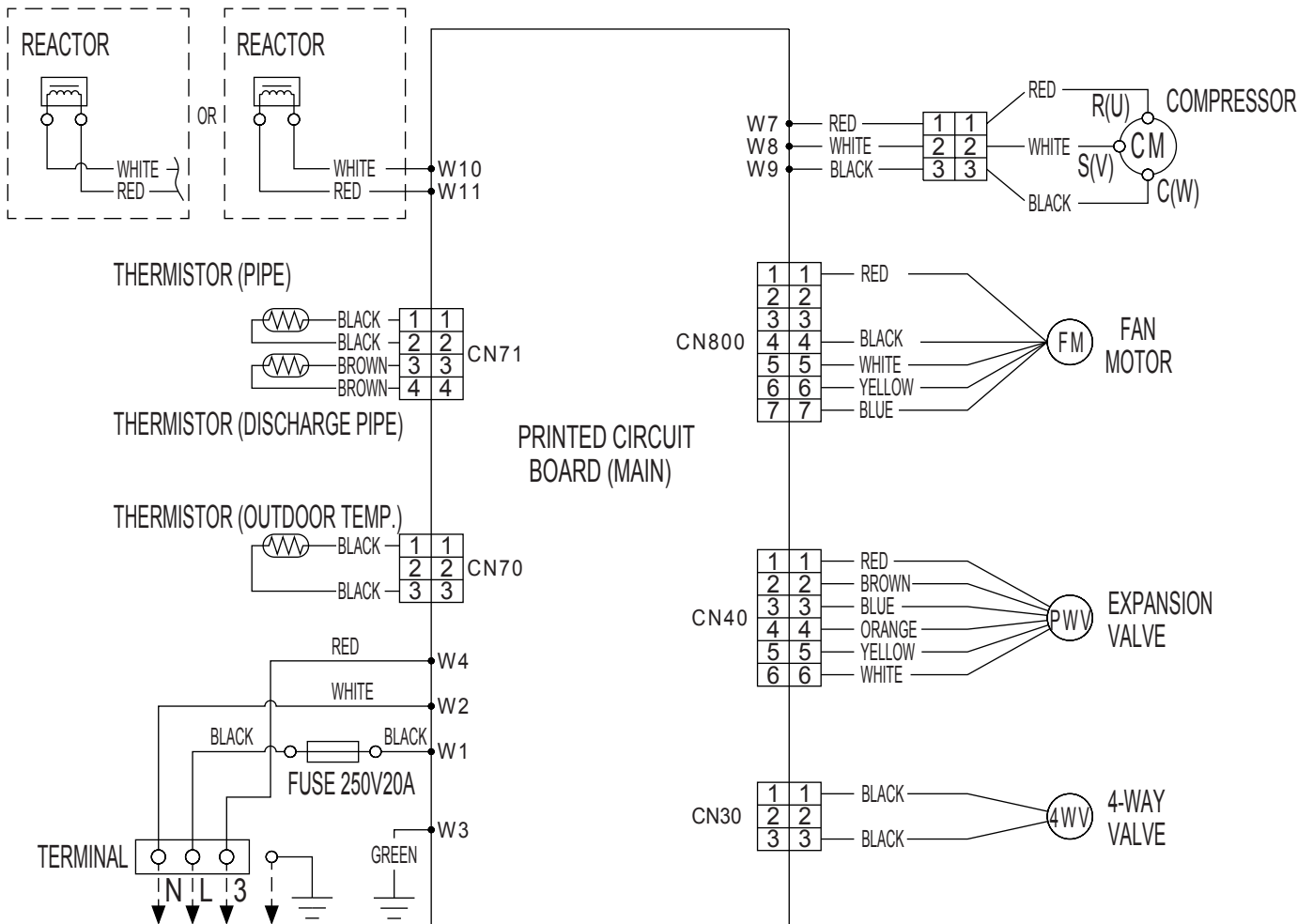

INDOOR PCB CIRCUIT DIAGRAM

Models : RSB09LDC, RSB12LDC

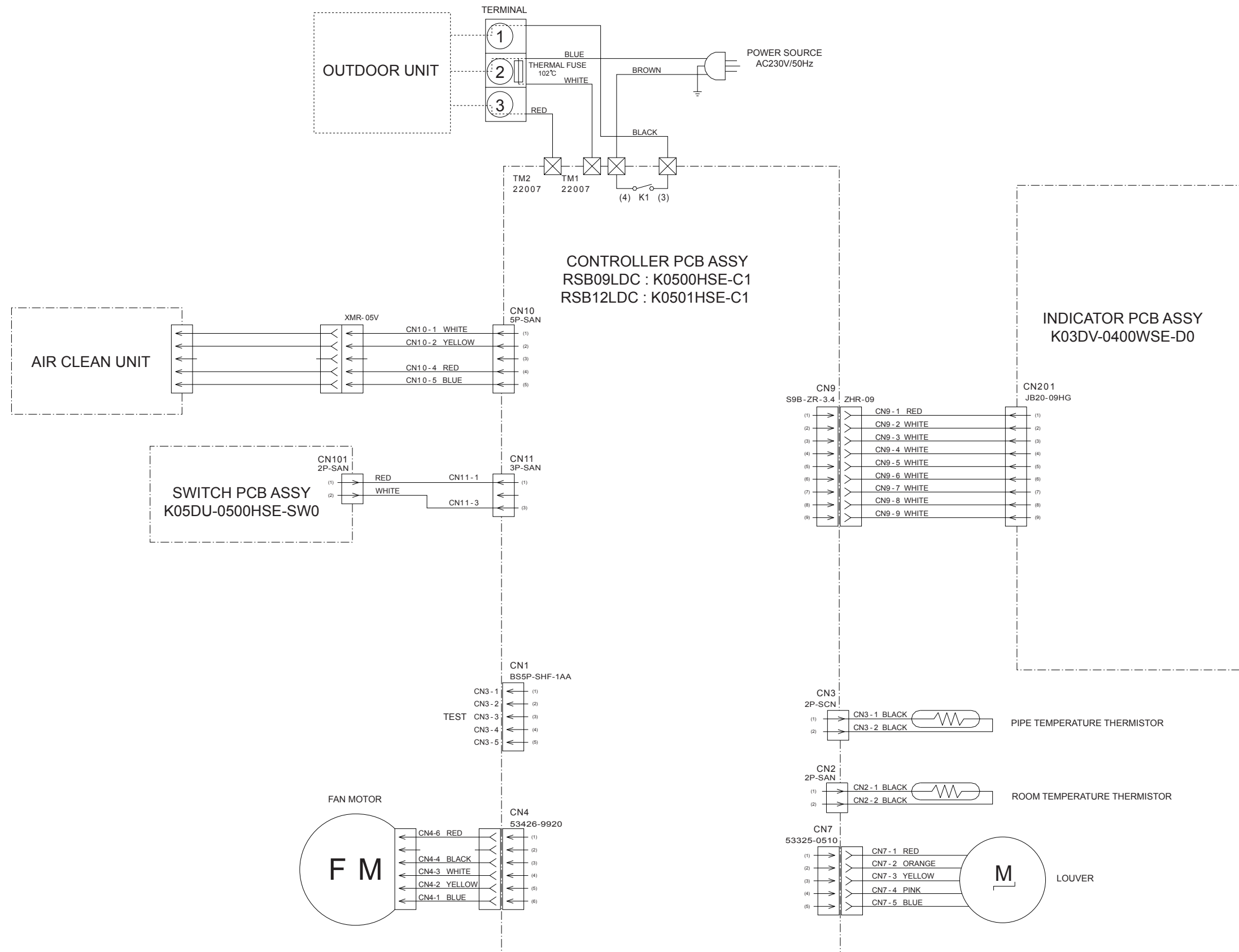

Models : RSB09LDC
RSB12LDC

INDICATOR PCB
K03DV-0400WSE-D0

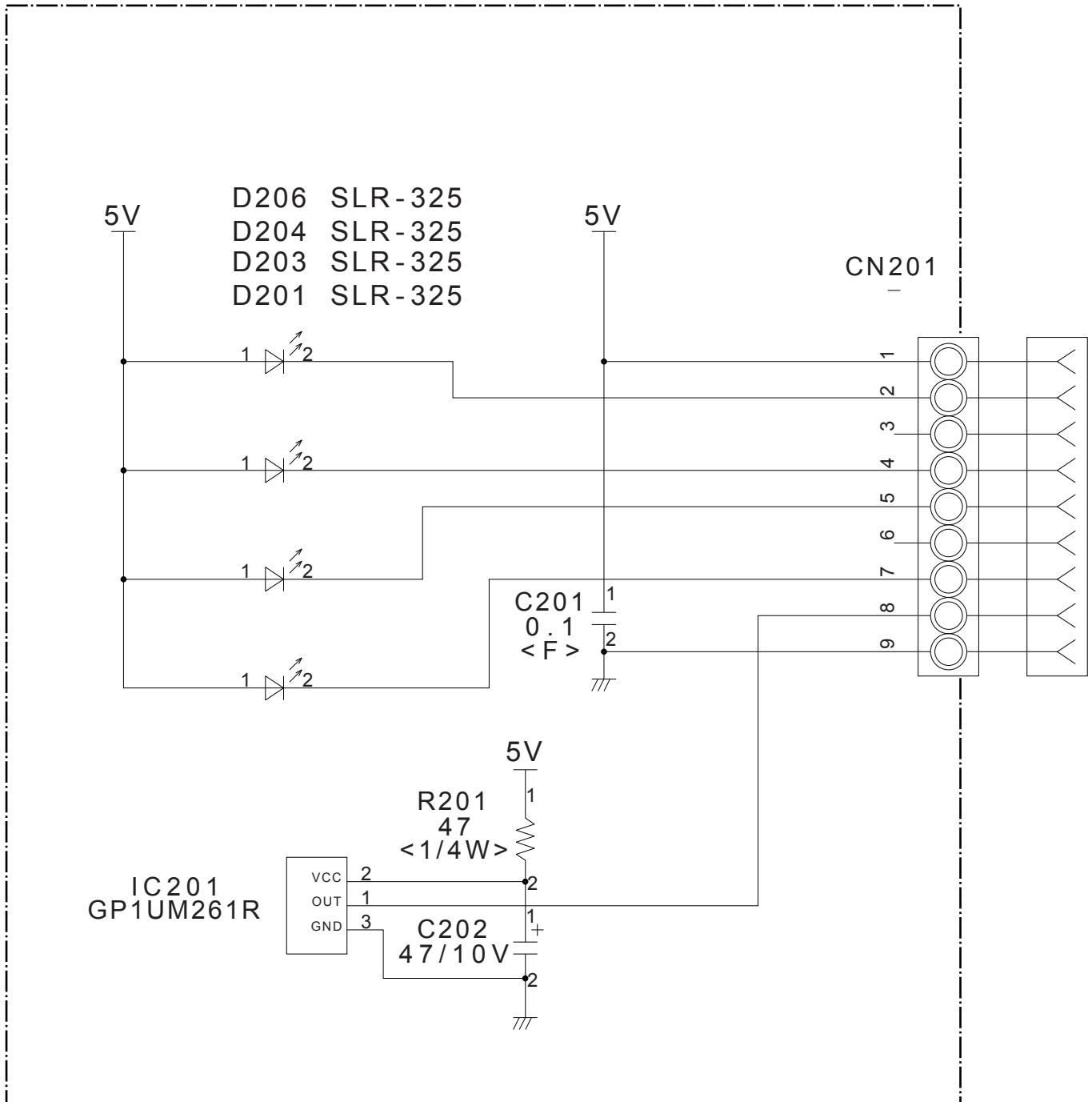

OUTDOOR PCB CIRCUIT DIAGRAM

Models : ROS09LDC
ROS12LDC

INVERTER ASSEMBLY
ROS09LDC : EZ-005AHUE
ROS12LDC : EZ-005BHUE

CONTROLLER PCB ASSEMBLY
ROS09LDC : K05CM-0503HUE-C1
ROS12LDC : K05CM-0504HUE-C1

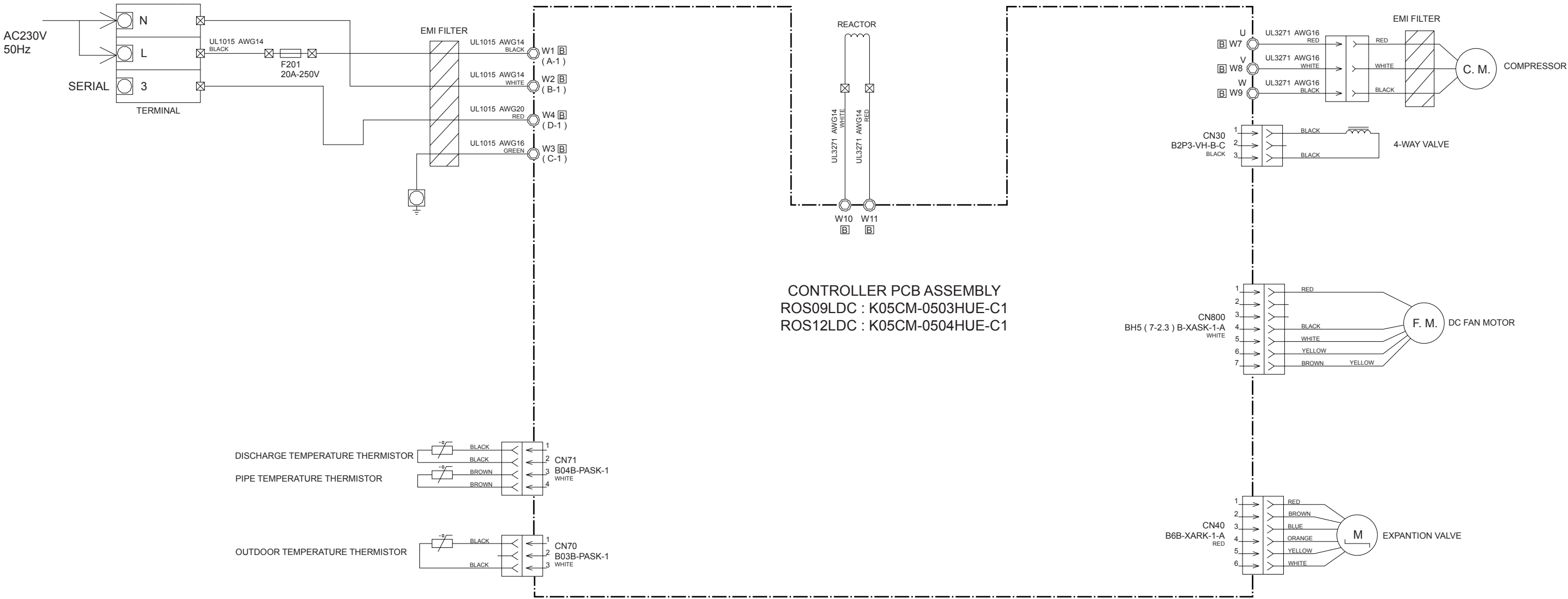

Models : ROS09LDC
ROS12LDC

CONTROLLER PCB ASSEMBLY
ROS09LDC : K05CM-0503HUE-C1
ROS12LDC : K05CM-0504HUE-C1

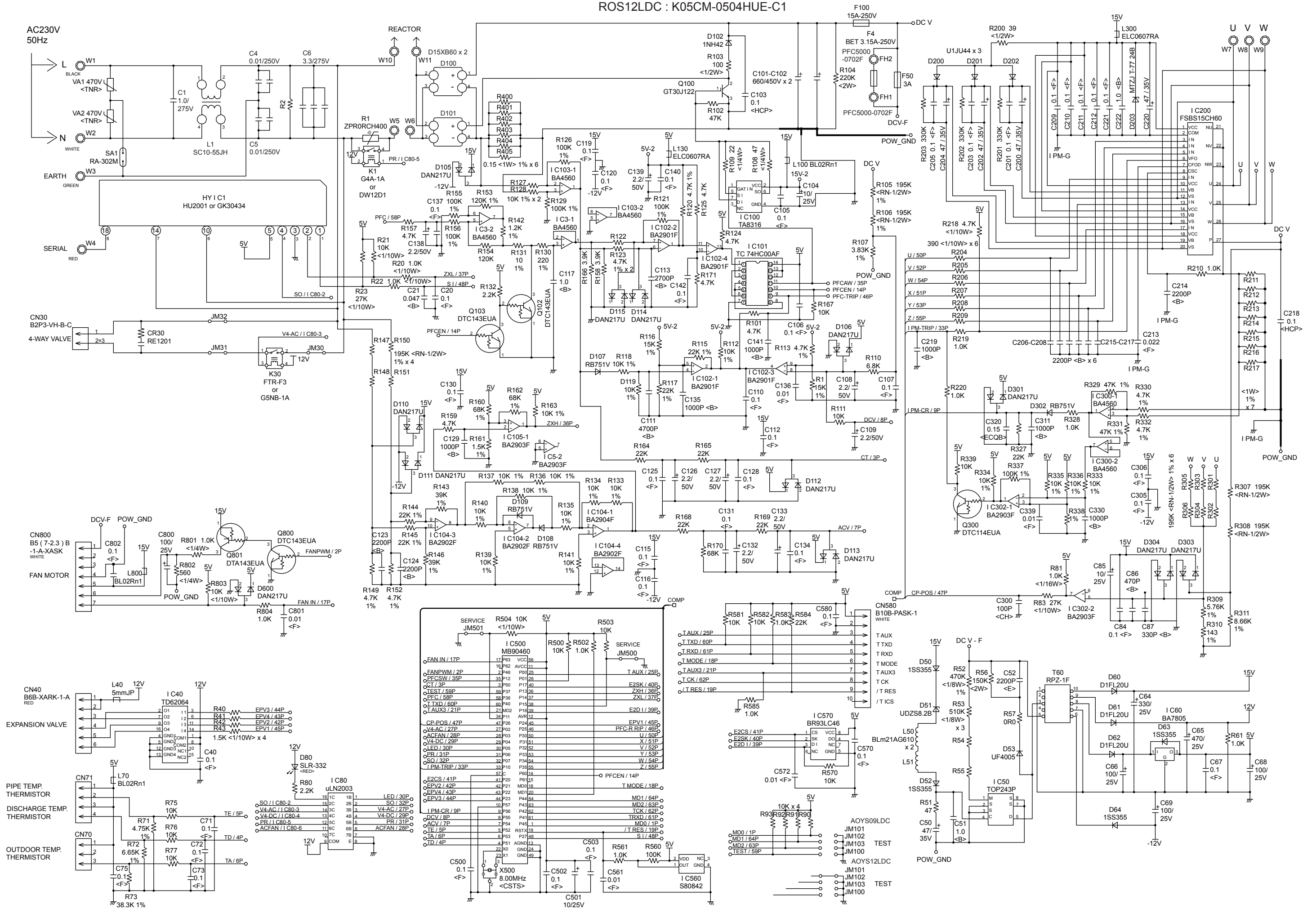

ERROR CONTENTS

Error	Display		Error
	Operation LED	Timer LED	
Serial signal error	Off	2 flash	Serial signal (reverse) error, at operation start up
		3 flash	Serial signal (reverse) error, during operation
		4 flash	Serial signal (forward) error, at operation start up
		5 flash	Serial signal (forward) error, during operation
Indoor unit thermistor error	2 flash	2 flash	Indoor temperature thermistor open / short
		3 flash	Heat exchanger middle thermistor open / short
Outdoor unit thermistor error	3 flash	2 flash	Discharge thermistor open / short
		3 flash	Heat exchanger thermistor open
		4 flash	Outdoor temperature thermistor open / short
Indoor unit control error	4 flash	2 flash	Forced automatic SW welded
		3 flash	Main relay welded
		4 flash	Power interruption error
		7 flash	VDD permanent stop protection
		8 flash	reverse VDD permanent stop protection
Outdoor unit control error	5 flash	2 flash	Current trip error
		3 flash	CT abnormal
		5 flash	Compressor location detection error
		6 flash	Outdoor unit fan drive system abnormal
Indoor fan motor error	6 flash	2 flash	Abnormal lock
		3 flash	Abnormal rotation
Refrigerant cycle error	7 flash	2 flash	Discharge Temperature abnormal
		3 flash	Cooling high pressure abnormal rise
Optional function error	8 flash	4 flash	PFC circuit error
Model error	Blinking	Blinking	Model error

DISASSEMBLY ILLUSTRATION

Models :
RSB09LDC
RSB12LDC

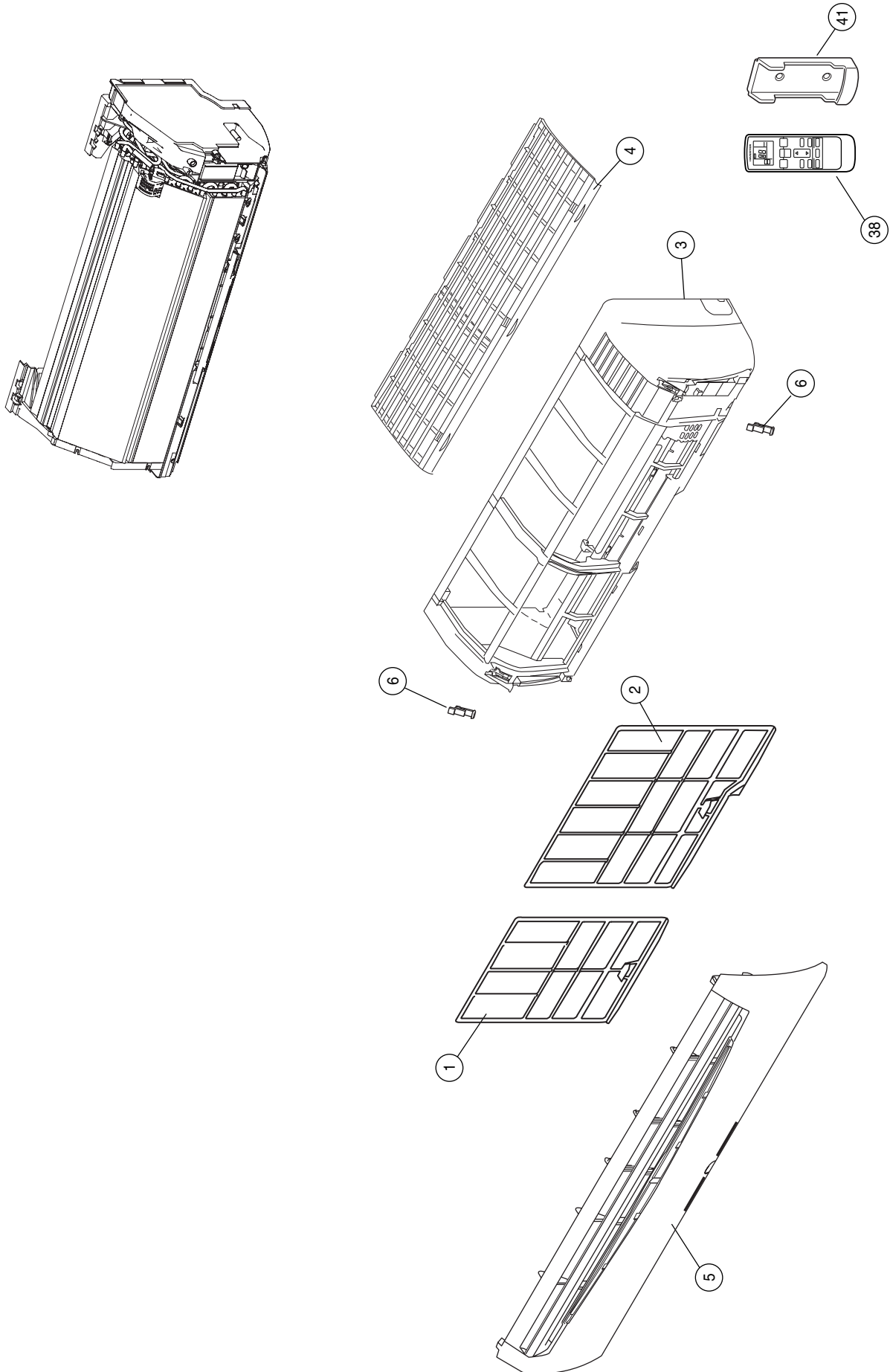

Models :
RSB09LDC
RSB12LDC

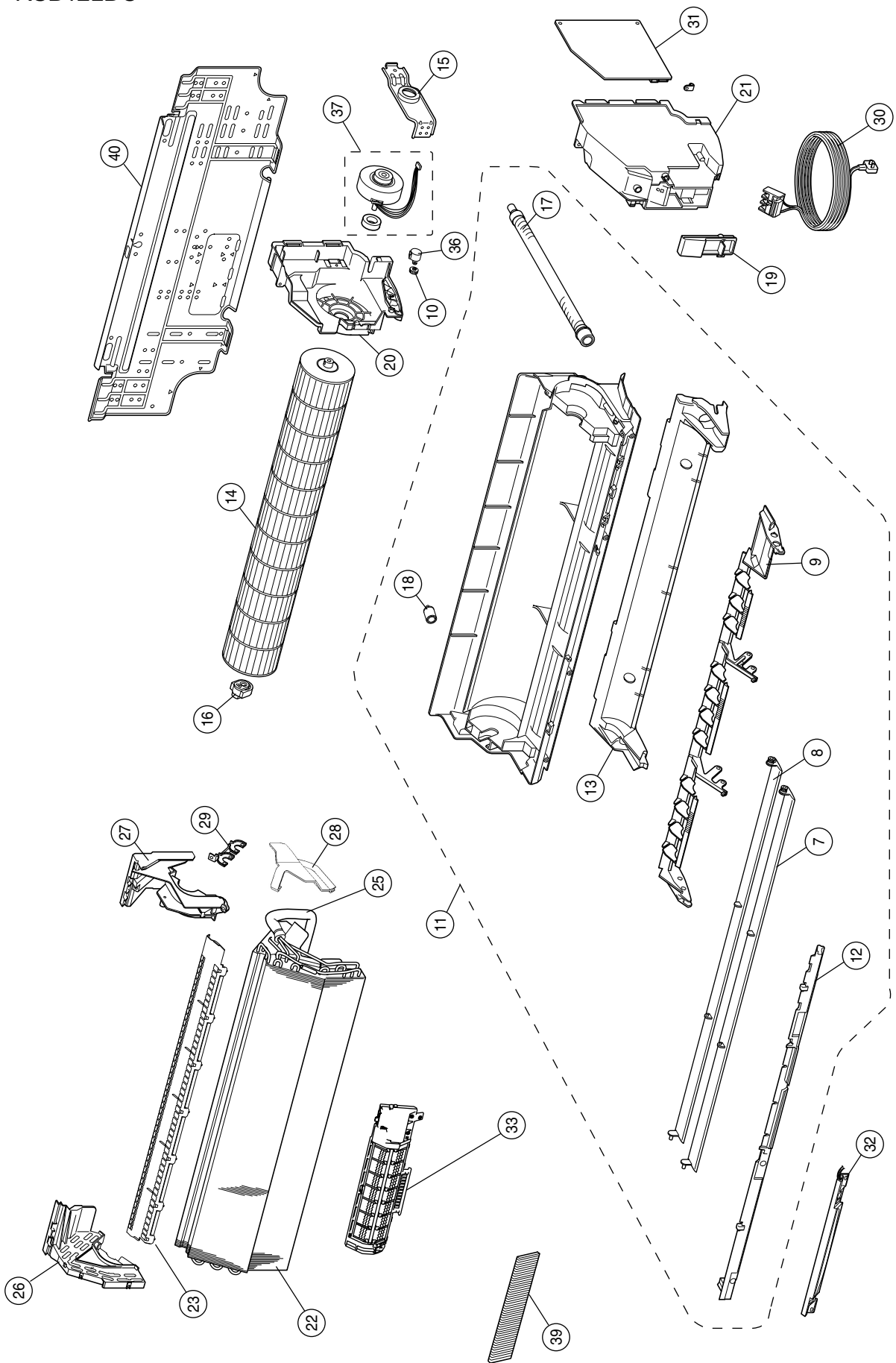

Models :
ROS09LDC
ROS12LDC

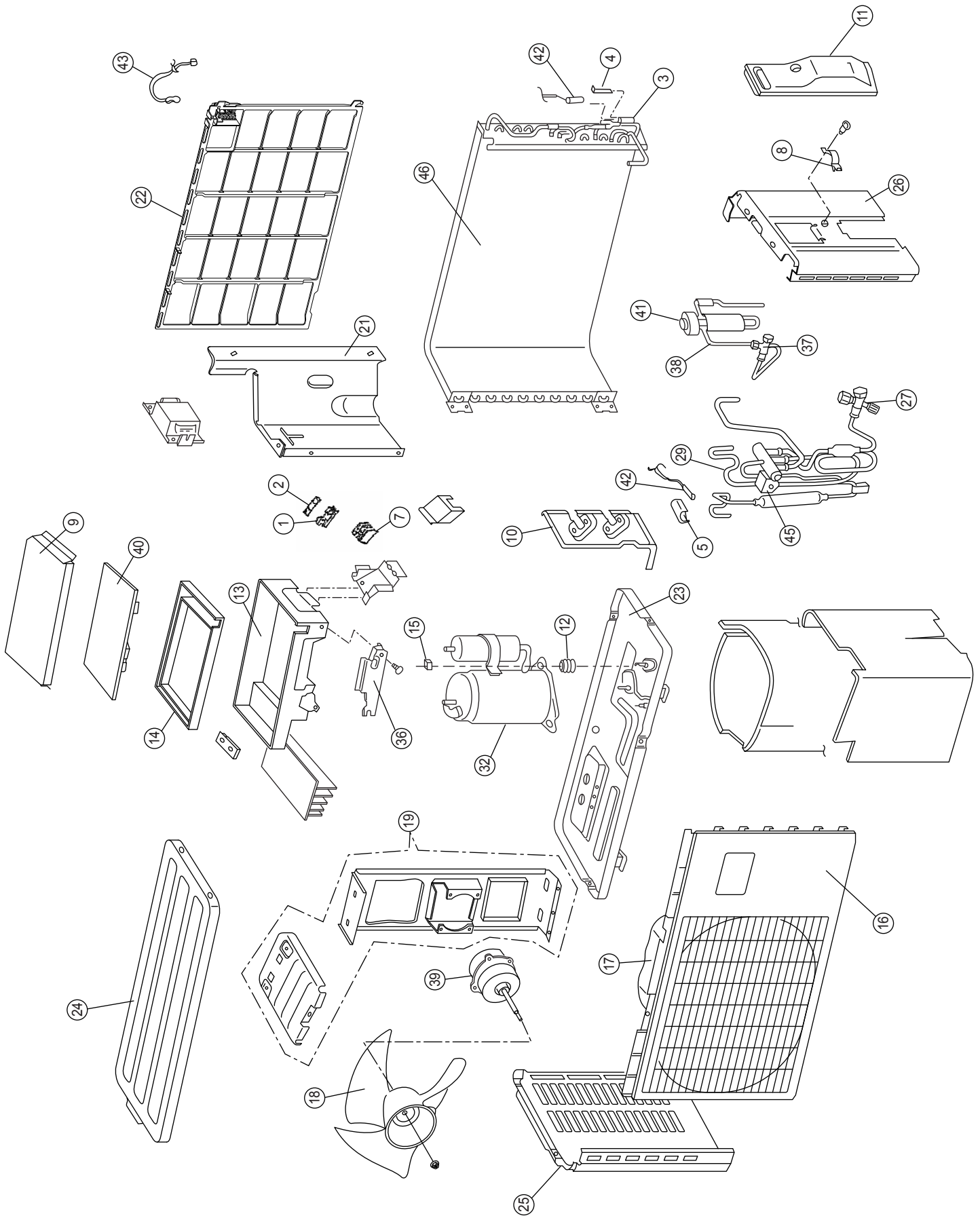

PARTS LIST

INDOOR UNIT

Ref. No.	Description	Part No.		Ord. Q'ty
		RSB09LDC	RSB12LDC	
1	Air Filter-L	9312920013	9312920013	
2	Air Filter-R	9312921010	9312921010	
3	Front Panel	9312914029	9312914029	
4	Top Grill	9313948016	9313948016	
5	Intake Grille Assy	9313157098	9313157098	
6	Clamper (Grille)	9306755010	9306755010	
7	Louver-U	9309991033	9309991033	
8	Louver-Z	9309992030	9309992030	
9	Holder (Louver) Assy	9309993013	9309993013	
10	Gear-A	9309994003	9309994003	
11	Casing Assy	9311354079	9311354079	
12	Cover (Casing)-F	9309987005	9309987005	
13	Cover (Casing)-B	9314160011	9314160011	
14	Crossflow Fan Assy	9307836015	9307836015	
15	Clamper (Motor)	9310102008	9310102008	
16	Bearing-C Assy	9306628017	9306628017	
17	Hose (Drain) Assy	9314147012	9314147012	
18	Cap (Drain) Assy	9314493010	9314493010	
19	Wire Clamper	9311946014	9311946014	
20	Box Switch	9312908011	9312908011	
21	Cover (Switch)	9312909018	9312909018	
22	Evaporator Total Assy	9313099015	9313099015	
23	Filter Guide	9313920012	9313920012	
25	H-Ins. (Pipe)-E	9304607007	9304607007	
26	Evaporator Holder-L Assy	9313174019	9313174019	
27	Evaporator Holder-R	9309983014	9309983014	
28	Water Seal	9312912018	9312912018	
29	Bracket (Eva.)	9310464007	9310464007	
30	Power Cord Assy	9900339036	9900339012	
31	Controller PCB Assy	9707116014	9707116021	
32	Indicator PCB Assy	9705375024	9705375024	
33	Air Cleaner Assy	9313148041	9313148041	
36	Motor, Step	9900139025	9900139025	
37	Motor, Brushless DC	9602109012	9602109012	
38	Remote Control Unit Assy	9315027047	9315027047	
39	Air Clean Filter	9313275013	9313275013	
40	Bracket Panel Assy	9310001004	9310001004	
41	Remote Control Unit Holder	9305642045	9305642045	
----	Room Temperature Thermistor	9700801108	9700801108	
----	Pipe Temperature Thermistor	9702039042	9702039042	
----	Transformer, Switch T1	9705054011	9705054011	
----	Varister VA1	0000785020	0000785020	
----	Fuse FSL 250 3.15(EM)	0600376062	0600376062	
----	Fuse Holder FH1-FH2	0500158072	0500158072	
----	Relay DW12D1 K1	9704185013	9704185013	
----	Manual Auto Switch SW1	9703476013	9703476013	
----	Cover (Display)	9312917013	9312917013	
----	Display Cover	9312918010	9312918010	
----	Receiver Window	9312919017	9312919017	
----	Holder (Outdoor Thermistor)	9307178023	9307178023	

OUTDOOR UNIT

Ref. No.	Description	Part No.		Ord. Q'ty
		ROS09LDC	ROS12LDC	
1	Fuse Holder	0501454012	0501454012	
2	Fuse	0600382018	0600382018	
3	Thermister Holder Pipe	313714262805	313714262805	
4	Thermistor Spring-A	313728262708	313728262708	
5	Thermistor Spring	9300089012	9300089012	
7	Terminal	9306489038	9306489038	
8	Cord Clamp	9307271014	9307271014	
9	Cover (Case)	9309913011	9309913011	
10	Bracket Valve	9310229026	9310229026	
11	Cover (Switch)	9310979013	9310979013	
12	Rubber Cushion	9312680016	9312680016	
13	Inverter Case Assy	9312972029	9312972029	
15	Nut Special Assy	9313452018	9313452018	
16	Front Panel	9313806026	9313806026	
17	Fan Ring	9313807016	9313807016	
18	Propeller Fan	9313808013	9313808013	
19	Bracket (Motor) Assy	9313990015	9313990015	
21	Separator-B	9313815011	9313815011	
22	Protective Net	9313941024	9313941024	
23	Base Assy (Painted)	9313987015	9313987015	
24	Top Panel (Painted)	9313989026	9313989026	
25	Cabinet Left (Painted)	9313992019	9313992019	
26	Cabinet Right (Painted)	9313995034	9313995034	
27	3-Way Valve Assy	9314022012	9314022012	
29	4-Way Valve Assy	9314093012	9314093012	
32	Compressor Assy	9315206015	9315206015	
36	Cover (Inverter Case)	9314507014	9314507014	
37	2-Way Valve Assy	9314554018	9314554018	
38	Pulse Motor Valve Assy	9314557019	9314557019	
39	Fan Motor	9602111015	9602111015	
40	Inverter PCB Assy	9707039047	9707039054	
41	Expansion Valve Coil	9900057039	9900057039	
42	Thermistor Assy	9900148027	9900148027	
43	Thermistor (Outdoor Temp)	9900210038	9900210038	
45	Solenoid	9970033018	9970033018	
46	Condenser Assy	9314033018	9314106019	
---	Emblem Rear	9312637034	9312637034	

STANDARD ACCESSORIES

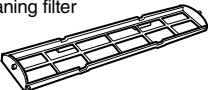
Name and Shape	Part No.
Wall hook bracket 	9310001004
Remote control unit 	9315027047
Remote control unit holder 	9305642045
Battery (penlight) 	0600185527
Cloth tape 	9310519004
Tapping screw (big) (φ 4 x 25) 	0700076046
Tapping screw (small) (φ 3 x 12) 	0700019036
Air cleaning filter 	9312153015
	9311925033
Air cleaning filter frame 	9306602017

0601G2985